

# Avoiding self: two Tn7-encoded proteins mediate target immunity in Tn7 transposition

Anne E. Stellwagen and Nancy L. Craig<sup>1</sup>

Department of Molecular Biology and Genetics and the Howard Hughes Medical Institute, Johns Hopkins University School of Medicine, 725 N. Wolfe Street, Baltimore, MD 21205, USA

<sup>1</sup>Corresponding author  
e-mail: nancy\_craig@qmail.bs.jhu.edu

**The bacterial transposon Tn7 exhibits target immunity, a process that prevents Tn7 from transposing into target DNAs that already contain a copy of the transposon. This work investigates the mechanism of target immunity *in vitro*. We demonstrate that two Tn7-encoded proteins—TnsB, which binds specifically to the ends of Tn7, and TnsC, the ATP-dependent DNA binding protein—act as a molecular switch to impose immunity on target DNAs containing Tn7 (or just Tn7 ends). TnsC binds to target DNA molecules and communicates with the Tn7 transposition machinery; here we show that target DNAs containing Tn7 ends are also bound and subsequently inactivated by TnsB. Protein–protein interactions between TnsB and TnsC appear to be responsible for this inactivation; the target DNA promotes these interactions by tethering TnsB and TnsC in high local concentration. An attractive model that emerges from this work is that TnsB triggers the dissociation of TnsC from the Tn7 end-containing target DNA; that dissociation depends on TnsC’s ability to hydrolyze ATP. We propose that these interactions between TnsB and TnsC not only prevent Tn7 from inserting into itself, but also facilitate the selection of preferred target sites that is the hallmark of Tn7 transposition.**

**Keywords:** ATP binding protein/DNA binding/molecular switch/protein–DNA interaction/transposition

## Introduction

DNA molecules are the substrates for a variety of processes, including replication, transcription and recombination. Many positive regulatory mechanisms have been described which favor the selection of certain DNAs as substrates for one of these processes. In some situations, however, the positive features of a DNA can be overridden by negative regulatory mechanisms. For example, some transcriptional units are ‘silenced’ by being packaged within specialized chromatin structures which prevent interactions with RNA polymerase (Loo and Rine, 1995). Eukaryotic origins of replication also become ‘silent’ after initiating DNA replication, as part of the cell cycle control that permits an origin to fire once and only once during S phase (Muzi-Falconi *et al.*, 1996; Wuarin and Nurse, 1996).

Negative regulatory mechanisms can also influence the

selection of target sites in transposition. The bacterial transposons Tn3 and Tn7 and the bacteriophage Mu are sensitive to a process called target immunity, in which a target molecule that already contains a copy of one of these elements is prevented from receiving further insertions of that element (Robinson *et al.*, 1977; Hauer and Shapiro, 1984; Reyes *et al.*, 1987). Thus, the target DNA becomes ‘silent’ or ‘immune’ to the transposition machinery.

The signal that confers immunity to a target DNA is provided by the ends of the resident Tn3, Tn7 or Mu element. Transposon ends contain special sequences that are the substrates for the DNA breakage and joining reactions that move the element from one DNA molecule to another; transposon ends also contain binding sites for transposase, the enzyme which executes the DNA breakage and joining reactions (reviewed by Mizuuchi, 1992). The presence of Tn3, Tn7 or Mu ends in a target plasmid reduces the frequency of transposition into that plasmid 100- to 1000-fold *in vivo*; however, transposition into other target molecules which do not contain transposon ends is not inhibited (Lee *et al.*, 1983; Darzins *et al.*, 1988; Arciszewska *et al.*, 1989). Therefore, target immunity is essentially a *cis*-acting phenomenon that prevents new insertions from occurring ‘close’ to transposon ends.

How close is ‘close’? In the case of Tn7, large (60 kb) derivatives of the *Escherichia coli* F plasmid are protected from Tn7 transposition when the plasmid contains Tn7 end sequences (Arciszewska *et al.*, 1989). Transposition is inhibited over even larger distances in the *E. coli* chromosome: the presence of Tn7 ends was shown to reduce insertions into chromosomal sites 190 kb away (DeBoy and Craig, 1996). However, transposition into a target site 1.9 Mb from the Tn7 ends was not affected, demonstrating that the Tn7 ends do not cause a global inhibition of transposition (DeBoy and Craig, 1996).

The ability to discriminate between targets that are ‘close’ and ‘far’ from Tn7 ends may be useful in promoting the spread and survival of Tn7. Short-range transposition events would be discouraged; instead, the spread of the transposon to distant sites in the chromosome and new plasmids would be favored. Immunity would also discourage events that could potentially destroy Tn7, such as intramolecular transposition events or the hopping of one copy of Tn7 into another. Thus, target immunity plays a key role in determining what target sites the Tn7 transposition machinery will select.

The Tn7 transposition machinery also evaluates a potential target DNA for positive features. Tn7 transposition occurs at high frequency into a single site in the *E. coli* chromosome called *attTn7* (Barth *et al.*, 1976; Lichtenstein and Brenner, 1982). Plasmids undergoing conjugation are also preferred targets for Tn7 transposition (Wolkow *et al.*, 1996). Thus, *attTn7* and conjugating plasmids contain positive signals that attract the transposition machinery to

these target DNAs. Different combinations of the Tn7-encoded proteins TnsA, TnsB, TnsC, TnsD and TnsE are used to select these different targets: TnsABC+D promotes transposition into *attTn7*, whereas TnsABC+E promotes transposition into conjugating plasmids (Rogers *et al.*, 1986; Waddell and Craig, 1988). Target immunity is observed in both the TnsABC+D and TnsABC+E transposition pathways (Arciszewska *et al.*, 1989), suggesting that the negative signal provided by a Tn7 end is dominant to the positive signals which might also be contained on a potential target molecule.

Tn7 transposition into *attTn7* has been reconstituted *in vitro* using purified proteins (Bainton *et al.*, 1993), and the roles of the Tns proteins in executing Tn7 transposition have been investigated. TnsA and TnsB act interdependently to catalyze the chemical steps of Tn7 transposition, thus TnsA+B constitutes the Tn7 transposase (May and Craig, 1996; Sarnovsky *et al.*, 1996). TnsB binds specifically to the transposon ends (Arciszewska and Craig, 1991; Arciszewska *et al.*, 1991; Tang *et al.*, 1991), while TnsA is likely recruited to the transposon ends through protein-protein interactions with TnsB.

The TnsA+B transposase by itself is not catalytically active; TnsC, TnsD and an appropriate target DNA are also required (Bainton *et al.*, 1993; Gary *et al.*, 1996). TnsD is an *attTn7*-specific DNA-binding protein which recruits TnsC, an ATPase that is also an ATP-dependent DNA-binding protein, to *attTn7* targets. TnsC–TnsD–*attTn7* complexes, in turn, interact with the TnsA+B transposase and activate its breakage and joining activities (Gamas and Craig, 1992; Bainton *et al.*, 1993; A.Stellwagen and N.L.Craig, in preparation). TnsC has been proposed to be a key connector between the target site and the TnsA+B transposase, and the ATP state of TnsC is hypothesized to regulate its ability to forge that connection (Bainton *et al.*, 1993; Stellwagen and Craig, 1997).

Tn7 transposition occurs by a cut-and-paste mechanism, in which the element is first excised from a donor site and then inserted into a target DNA (Bainton *et al.*, 1991). The nature of the target DNA regulates both of these steps *in vitro*: if an *attTn7* target molecule is omitted from the reaction, virtually no transposition intermediates or products are seen. Target immunity is reproduced in the *in vitro* Tn7 transposition reaction (Bainton *et al.*, 1991, 1993); the evaluation of Tn7 end-containing targets also occurs early in the course of the reaction. No transposition products or intermediates are observed when the target DNA contains *attTn7* but also carries a Tn7 right end. Therefore, Tn7 end-containing target DNAs are immune to Tn7 transposition not because they fail to capture excised transposons, but because they fail to provoke the excision of the transposon in the first place.

*In vitro* approaches have been previously used to investigate target immunity in Mu transposition. Adzuma and Mizuuchi (1988, 1989) demonstrated that Mu target immunity results from the redistribution of the regulatory protein MuB from target DNAs containing Mu ends to target DNAs without ends. This redistribution is promoted by the MuA transposase, and requires ATP hydrolysis. However, it has been unclear whether this mechanism would be unique to Mu or whether it would apply to other transposons. In particular, it has been unclear how Tn7—

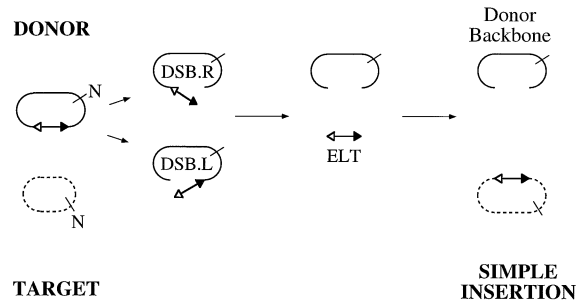

**Fig. 1.** The Tn7 transposition pathway. The mTn7 element is excised from the donor substrate (solid line) by double-strand breaks and then joined to the target DNA (dashed line) to generate a simple insertion. Donor molecules which have a double-strand break at the left or right end (DSB.L or DSB.R) appear transiently as intermediates in the reaction, as does the fully excised linear transposon (ELT). The *cis*-acting recombination sequences at the transposon ends are indicated by an open triangle (left end) and a closed triangle (right end). The positions of *Nde*I (N) sites in the donor and target plasmids are also indicated.

with its multiple proteins and multiple target selection pathways—might adapt this immunity mechanism.

In this work, we have investigated the mechanism of Tn7 target immunity. We find that the key proteins responsible for Tn7 target immunity are TnsB, the transposon end-binding protein, and TnsC, the ATP-dependent target DNA-binding protein. When TnsB and TnsC are in high local concentration (i.e. when both are localized to a Tn7 end-containing target DNA), immunity is imposed on that target. An attractive model that emerges from this work is that TnsB promotes the dissociation of TnsC from Tn7 end-containing target DNAs, through an ATP-dependent mechanism. Thus, TnsB appears to impose target immunity by influencing the distribution of TnsC among potential target DNAs. We discuss the similarities between the mechanisms by which Tn7 and Mu achieve target immunity, and we discuss how Tn7 exploits this mechanism not only to avoid immune targets but also to select preferred targets for Tn7 transposition.

## Results

### *Tns* proteins involved in target use and target immunity

Tn7 transposition has been reconstituted *in vitro* with TnsA, TnsB, TnsC, TnsD and two required cofactors, ATP and  $Mg^{2+}$  (Bainton *et al.*, 1993). These Tns proteins and cofactors direct the transposition of a mini-Tn7 element from a donor plasmid to an *attTn7*-containing target plasmid (Figure 1). The mini-Tn7 element (mTn7) contains an antibiotic resistance cassette flanked by functional Tn7 end sequences. Transposition proceeds via a cut-and-paste mechanism, in which the element is excised from the donor site by double-strand breaks at the transposon ends and then joined to the target molecule to generate a simple insertion.

The assembly of Tns proteins with the *attTn7* target DNA is a critical step in Tn7 transposition. Previous work has demonstrated that the *attTn7*-specific DNA-binding protein TnsD and the ATP-dependent DNA-binding protein TnsC form a complex on the target DNA which can then interact with the TnsA+B transposase to trigger the initiation of transposition (Bainton *et al.*, 1993). However,

TnsC–TnsD–*attTn7* target complexes form very inefficiently in the presence of  $Mg^{2+}$ . Therefore, Tn7 transposition reactions are staged: the proteins and DNAs are first incubated under low  $Mg^{2+}$  conditions to promote target complex assembly (a step called the ‘preincubation’), then  $Mg^{2+}$  is added to initiate transposition. No additional target complexes are formed after the addition of  $Mg^{2+}$ . Only the components of the target complex—TnsC, TnsD, ATP and the *attTn7* target DNA—need to be present during the low  $Mg^{2+}$  preincubation; the presence of the donor DNA, TnsA or TnsB at this step is not required (Bainton *et al.*, 1993).

Having established which Tns proteins are involved in target use, our first goal in this work was to determine which Tns proteins are involved in target immunity. We carried out order-of-addition experiments which were staged somewhat differently than the reactions described above: both the donor and target DNAs were separately preincubated with Tns proteins and then combined to initiate transposition (Figure 2A). The donor DNA was always preincubated with the TnsA+B transposase and  $Mg^{2+}$ . By contrast, the proteins present during the target preincubation were varied. Any protein(s) omitted from the target preincubation were added when the donor and target preincubations were combined, so that the final composition of each reaction was the same but the proteins present at the time of target complex assembly were different.

Target immunity was observed when all four Tns proteins were preincubated with the target DNAs: 50-fold fewer insertions occurred into the target DNA containing a Tn7 right end than the target lacking Tn7 ends (Figure 2B, lane 1). However, immunity was severely compromised when TnsC and TnsD were the only proteins present in the target preincubation: a 20-fold increase in insertions into the Tn7 end-containing target was seen (Figure 2B, lane 2). Including TnsB in the target preincubation fully restored the discrimination between targets with and without Tn7 ends (lane 4); the presence of TnsA in the target preincubation was not required (lane 3). Consistent with the results of Bainton *et al.* (1993), omitting TnsC or TnsD from the target preincubation eliminated all insertion events (Figure 2B, lanes 5 and 6). Similarly, omitting the target DNA without ends from the target preincubation also blocked transposition; this target could not be utilized when it was added after the preincubations were combined (lane 7). Taken together, these results suggest that although TnsC and TnsD are important for target use, they are not sufficient to discriminate between target DNAs with and without Tn7 ends. TnsB, the transposon end-binding protein, must also be present during the assembly of target complexes for Tn7 end-containing targets to be recognized and avoided.

These observations reveal that TnsB plays multiple roles in Tn7 transposition. As part of the TnsA+B transposase, TnsB is involved in promoting insertions into target DNAs. In fact, mutational analysis suggests that the active site responsible for target joining is likely in TnsB (Sarnovsky *et al.*, 1996). However, the experiment above suggests that TnsB is also involved in preventing insertions from occurring into target DNAs which contain Tn7 ends. This ‘regulatory’ activity of TnsB does not appear to require TnsA, in contrast to the ‘catalytic’ activity of

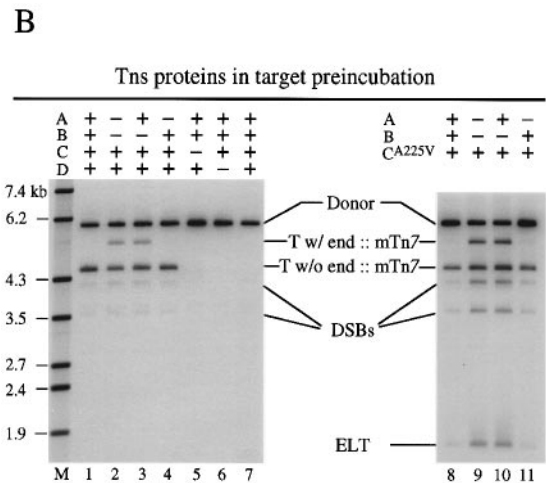
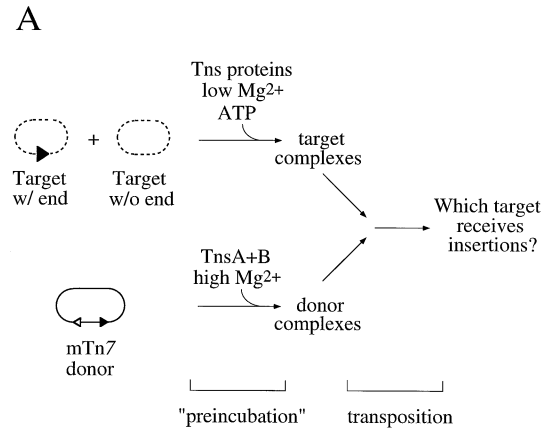

**Fig. 2.** Immunity requires TnsB to be present during target complex assembly. (A) The staging of the transposition reaction. Target plasmids with and without transposon ends were preincubated with ATP and some or all of the Tns proteins at the following relative concentrations: 0.5× TnsA, 0.5× TnsB, 1× TnsC (or TnsC<sup>A225V</sup>) and 1× TnsD (see Materials and methods). A mTn7 donor substrate was separately preincubated with 0.5× TnsA and 0.5× TnsB in 15 mM  $Mg^{2+}$ . The donor and target preincubations were combined after 20 min. Any proteins omitted from the target preincubation were then added to the reaction, so that the Tns proteins were ultimately present at 1× concentration in each reaction. The  $Mg^{2+}$  concentration was adjusted back to 15 mM and the incubations were continued for another 20 min. Reactions were then stopped and the DNAs were collected and analyzed. (B) Transposition reactions. The proteins included in each target preincubation are indicated above each lane. In lane 7, the target DNA without Tn7 ends was omitted from the target preincubation, but was added when the donor and target preincubations were combined. ‘T w/ end::mTn7’ indicates simple insertions of mTn7 into the target plasmid containing a Tn7 end (pLA11); ‘T w/o end::mTn7’ indicates simple insertions into the target plasmid without Tn7 ends (pKAO4-3).

TnsB which is dependent on the presence of TnsA. We will argue below that TnsB confers immunity to a target DNA by promoting the removal of TnsC from the target and thus reducing the target’s ability to interact with the transposase.

The data in Figure 2B suggest that the time at which TnsB is introduced into the transposition reaction influences whether TnsB’s regulatory or catalytic role predominates. Strong target immunity was established when TnsB was able to exert its regulatory effects prior to the initiation of Tn7 transposition. By contrast, when TnsB’s

addition was simultaneous with the initiation of transposition, considerable insertion occurred into Tn7 end-containing targets, suggesting that TnsB was interacting with many of these targets catalytically. Even under these conditions, however, the targets with and without Tn7 ends were not used equivalently: 2- to 3-fold fewer insertions were seen into targets containing Tn7 ends than into targets lacking Tn7 ends. This unequal target use may indicate that even as some Tn7 end-containing targets were being utilized by TnsA+B, others were being inactivated by TnsB. Additional experiments probing the time requirements for establishing target immunity are described below.

### **TnsD is not essential for Tn7 target immunity**

Tn7 transposition *in vitro* is dependent on TnsD for successful interactions with target DNA. Previous work has demonstrated that TnsD not only provides the *attTn7* specificity of the Tn7 transposition reaction but also activates the wild-type TnsABC machinery (Bainton *et al.*, 1993). Recently, gain-of-function mutations in TnsC have been identified which enable the TnsABC machinery to execute transposition in the absence of TnsD (Stellwagen and Craig, 1997). In this work, we have exploited the gain-of-function mutant TnsC<sup>A225V</sup>. Transposition promoted by TnsABC<sup>A225V</sup> occurs into many different target sites *in vivo*, yet responds to target signals and target binding proteins much like wild-type Tn7 transposition (Stellwagen and Craig, 1997).

We examined target discrimination in reactions containing TnsC<sup>A225V</sup> *in vitro* (Figure 2B, lanes 8–11). Although these reactions lacked TnsD, target immunity was still observed: 30-fold fewer insertions were seen into target DNAs containing Tn7 ends than into target DNAs lacking ends when TnsA, TnsB and TnsC<sup>A225V</sup> were preincubated with the target DNAs (lane 8). Once again, target immunity was not effectively imposed when TnsB was omitted from the target preincubation (Figure 2B, lanes 9 and 10). However, preincubating the target DNAs with TnsB and TnsC<sup>A225V</sup> was sufficient to allow target immunity to be established (lane 11). These experiments suggest that TnsC<sup>A225V</sup> promotes transposition into target DNAs in general, and that TnsB specifically discourages transposition from occurring into target DNAs containing Tn7 ends. TnsD, therefore, is not essential for Tn7 end-containing target DNAs to be recognized and avoided. While it is possible that TnsD contributes to the immunity response in the wild-type Tn7 transposition reaction, we propose that TnsB and TnsC—the transposon end-binding protein and the ATP-dependent target DNA-binding protein—undergo the primary interactions that are responsible for Tn7 target immunity.

The insertions generated in TnsABC<sup>A225V</sup> reactions without TnsB in the target preincubation were located in many different positions in the Tn7 end-containing target plasmid (data not shown). Including TnsB in the target preincubation reduced the level of insertions into all of those positions. Thus, Tn7 target immunity is not restricted to *attTn7* sites *in vitro*, but is conferred to the entire Tn7 end-containing plasmid.

### **TnsB binding sites comprise the DNA signal that confers immunity to a target plasmid**

The experiments above confirm the observations of Bainton *et al.* (1991) that a Tn7 right end contains the

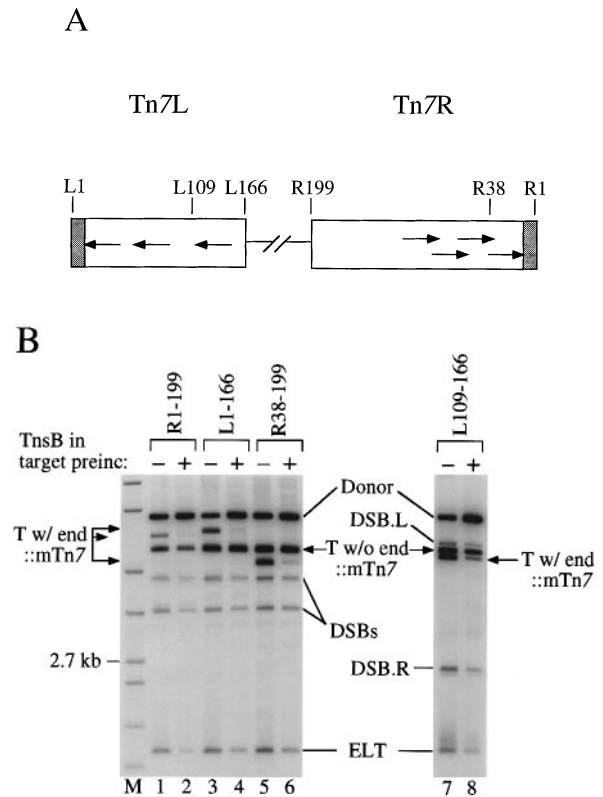

**Fig. 3.** Targets containing TnsB binding sites can be rendered immune. (A) The left and right ends of Tn7. TnsB binding sites (22 bp each) are indicated by arrows. The terminal eight nucleotides of each end are indicated by gray boxes. Nucleotide sequence positions are indicated above the ends, with the leftmost and rightmost nucleotides designated L1 and R1, respectively. (B) Transposition reactions. Reactions were staged as cartooned in Figure 2A. Target preincubations contained 20 ng TnsC<sup>A225V</sup> (except lanes 1–2, which contained 40 ng). 0.5× TnsB (12.5 ng) was added to the target preincubations (even lanes) or after the donor and target preincubations were combined (odd lanes). Donor preincubations contained 1× TnsA and 0.5× TnsB. Reaction products in lanes 1–6 were digested with *NdeI* prior to electrophoresis, whereas reaction products in lanes 7–8 were digested with *ScaI*. Arrows indicate insertions into plasmids containing the Tn7 end sequences R1–199 (pLA11), L1–166 (pRM2L), R38–199 (pLA62) or L109–166 (pLA77); insertions into a plasmid without Tn7 ends (pRM2) are also indicated. Each target plasmid is a slightly different size, therefore the insertion products are also of different sizes.

DNA signal(s) necessary for immunity to be imposed on a target plasmid. We investigated which features of the Tn7 right end are responsible for the immunity signal, and whether that signal is also present on the Tn7 left end. The left and right ends of Tn7 are structurally distinct (Figure 3A). Approximately 160 nucleotides from the left end and 90 nucleotides from the right end are required for efficient transposition (Arciszewska *et al.*, 1989; DeBoy and Craig, 1996). These sequences contain arrays of TnsB binding sites, with three sites on the left end and four overlapping sites on the right end (Arciszewska and Craig, 1991; Arciszewska *et al.*, 1991; Tang *et al.*, 1991). The terminal eight nucleotides of each end, along with the outermost TnsB binding site, form a 30 bp inverted repeat (Lichtenstein and Brenner, 1982; Arciszewska *et al.*, 1991); the CA-3'-OH dinucleotide at the tip of each end is critical for cleavage and joining events to occur (Gary *et al.*, 1996).

Plasmids containing different segments from either the right or left end of Tn7 were examined in the TnsC<sup>A225V</sup>-activated transposition reaction (Figure 3B); the same general principles have also been observed in reactions with TnsC+D (data not shown). The ability of each plasmid to serve as a target for Tn7 transposition was tested under two conditions: (i) without TnsB in the target preincubation, to evaluate the plasmid's intrinsic target activity; and (ii) with TnsB included in the target preincubation, to see whether the target activity changes when immunity can operate. Thus, controlling the presence or absence of TnsB during the target assembly period allowed immunity to be switched ON and OFF. A target plasmid without Tn7 end sequences was also included in each reaction as a control for transposition efficiency.

We found that the presence of either the right end or the left end of Tn7 in a target plasmid enabled immunity to be imposed on that plasmid: insertions into targets containing R1–199 sequences or L1–166 sequences decreased 13- to 20-fold when immunity was switched ON by including TnsB in the target preincubation (Figure 3B, compare lanes 1 and 2 with lanes 3 and 4). A truncated right end was also tested, in which the 30 bp terminal inverted repeat was removed but three TnsB binding sites were retained. Although this R38–199 end would not be predicted to support transposition when part of a mTn7 donor, R38–199 sequences could nonetheless confer immunity when present in a target DNA (Figure 3B, lanes 5 and 6). Even a single TnsB binding site in a target DNA was found to affect that target's activity (lanes 7 and 8). Although the transposition efficiencies of the reactions in lanes 7 and 8 were not identical, the activity of the target DNA containing the TnsB binding site was relatively more affected (6-fold rather than 2-fold) by the presence of TnsB than was the target DNA without the TnsB site.

Taken together, these observations suggest that TnsB binding sites provide the critical signal which allows immunity to be imposed on a target DNA. Additional features of Tn7 ends, such as the inverted repeat sequences at the tips of the element or the synaptic structure that can form with a pair of Tn7 ends, are thus important for catalysis but are not required for immunity. Although it remains possible that these features may contribute to the efficiency with which immunity is imposed, the binding of TnsB to a potential target DNA appears to be the primary event which renders that target immune.

### Communication between TnsB and TnsC

Target immunity is an example of 'action at a distance': a Tn7 end can inhibit insertion into an *attTn7* site many kilobases away in the case of plasmid targets (Arciszewska *et al.*, 1989), or even hundreds of kilobases away in the bacterial chromosome (DeBoy and Craig, 1996). Our working hypothesis is that an interaction between TnsB, bound to the transposon end, and TnsC, bound near a potential insertion site, is important in establishing target immunity. Various models have been proposed to account for long-distance interactions between proteins bound to different DNA sites, such as enhancers and promoters (reviewed by Wang and Giaever, 1988); those same models can be considered to explain how TnsB and TnsC might find each other on a Tn7 end-containing target DNA. One class of models would propose that TnsB and TnsC

communicate along the DNA. For example, TnsB could bind to its recognition site and nucleate an inhibitory structure that could spread down the DNA, inactivating or displacing TnsC; alternatively, TnsC could use its ATPase activity to track along the DNA, scanning for TnsB molecules. A second class of models would propose that TnsB and TnsC communicate through space via protein–protein interactions; those interactions would occur more frequently when the two proteins are both bound to a Tn7 end-containing target DNA and thus are in relatively high local concentration.

A classic experiment to differentiate between communication through space and communication through the DNA is to put the binding sites of interest on separate but tethered DNA molecules, namely catenated circles. Such an experiment was first done to probe the disposition of DNA sites required for target immunity in Mu transposition (Adzuma and Mizuuchi, 1989). Here we investigate whether immunity from Tn7 transposition can be conferred to a target plasmid that is catenated to (but not continuous with) a plasmid containing a Tn7 end. These experiments were performed with TnsABC+D, to take advantage of the target site-specificity of this reaction.

To generate a target substrate for this experiment, the right end of Tn7 and an *attTn7* sequence were cloned into a plasmid containing two recognition sites for  $\gamma\delta$  resolvase (Figure 4A). Recombination of the resulting plasmid generated two catenated circles, one containing the Tn7 end (which would bind TnsB) and the other containing the *attTn7* site (to which TnsC will be bound in the presence of TnsD). In our hands, ~50% of the DNA molecules became catenated (data not shown). The mixture of DNAs from the catenation reaction was used as targets for Tn7 transposition, allowing us to evaluate the target immunity of the unrecombined plasmid (in which *attTn7* and the Tn7 end were present on the same DNA molecule) and the catenated plasmid (in which *attTn7* and the Tn7 end were present on separate but tethered DNA circles).

As expected, the unrecombined '*attTn7* + end' plasmid was found to be immune; insertions into the '*attTn7* + end' target were reduced when immunity was switched ON by including TnsB in the target preincubation (Figure 4B, compare lanes 2 and 3, upper arrow). Interestingly, insertions into the *attTn7* circle catenated to the Tn7 end-containing circle were also affected when immunity was switched ON: 10-fold fewer insertions were seen into the catenated *attTn7* circle when TnsB was present in the target preincubation (Figure 4B, lanes 2 and 3, lower arrow). This result suggests that a Tn7 end can impose immunity on an *attTn7* plasmid that is tethered 'close' to that end.

If the proximity of the Tn7 end (and thus TnsB) to the *attTn7* target site is important in conferring immunity to that target, then unlinking the *attTn7* plasmid from the end-containing plasmid would be predicted to relieve the immunity effect. The *attTn7* circle was released from the Tn7 end-containing circle by treating the products of the catenation reaction with the restriction enzyme *NdeI* (Figure 4A). The unlinked *attTn7* target plasmid was no longer found to be immune: insertions accumulated into the unlinked *attTn7* target regardless of whether TnsB was present or absent from the target preincubation (Figure 4B, compare lanes 4 and 5, lower arrow). This result is

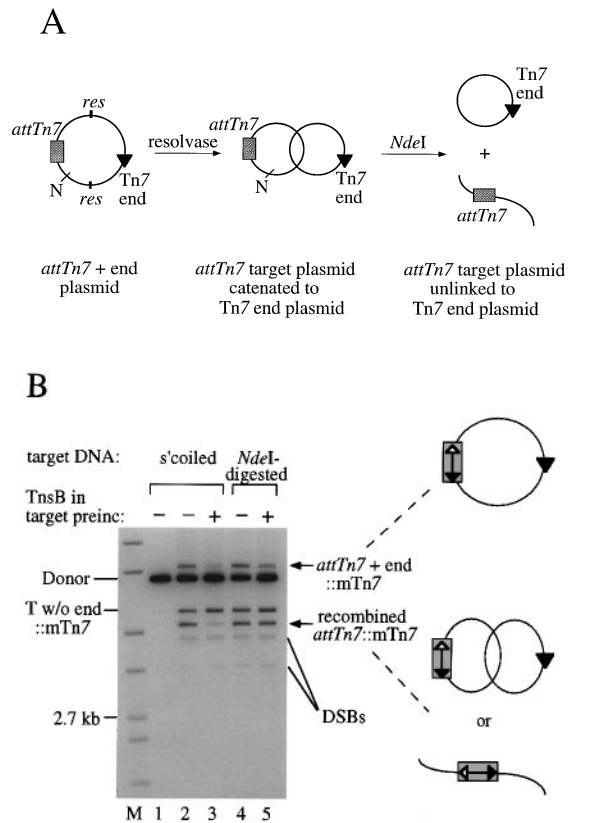

**Fig. 4.** Immunity can be conferred on a target plasmid catenated to a Tn7 end-containing plasmid. (A) Generating the catenated target substrates. The ‘attTn7 + end’ plasmid pRCAT2 contains a Tn7 right end (▼) and an attTn7 target sequence (gray box) between two recognition sites (res) for  $\gamma\delta$  resolvase. Resolvase-catalyzed recombination of pRCAT2 yields two catenated circles, one containing attTn7 and the other containing the Tn7 end. Treatment of the catenated product with NdeI (N) linearizes the attTn7 circle but leaves the Tn7 end-containing circle intact. (B) Transposition reactions. Reactions were staged as cartooned in Figure 2A. 50 ng of a target without ends (pRM2) were present in each reaction, along with ~100 ng each of the ‘attTn7 + end’ and ‘recombined attTn7’ targets. Transposition was evaluated with supercoiled target DNAs (lanes 1–3) or NdeI-linearized target DNAs (lanes 4–5). However, all DNAs were digested with NdeI prior to electrophoresis. Therefore, insertions into the catenated attTn7 target and the unlinked attTn7 target migrate to the same position in the gel. Target preincubations contained 1× TnsC and 1× TnsD (lanes 2–5); 0.5× TnsB was added to the target preincubation (lanes 3 and 5) or added after the donor and target preincubations were combined (lanes 2 and 4). Reactions in lane 1 contained no Tns proteins. Donor preincubations were as described for Figure 3. The upper arrow indicates insertions into the ‘attTn7 + end’ target, the lower arrow indicates insertions into the catenated attTn7 target or the unlinked attTn7 targets. Cartoons of these insertion products are also provided.

consistent with the hypothesis that TnsB must be in close proximity to a target DNA to impose immunity on that target.

It should be noted that the unlinked attTn7 targets have undergone two changes at once: they are no longer tethered to the Tn7 end, but they are also no longer supercoiled. Although it could be argued that both changes contribute to the loss of immunity of the unlinked attTn7 circle, other experiments have established that DNA supercoiling is not strictly required for immunity to be imposed on Tn7 end-containing target DNAs (data not shown). However, supercoiling may influence the effectiveness

with which TnsB and TnsC interact. We consistently observe that the 4.8 kb ‘attTn7 + end’ plasmid is less immune as a linear than as a supercoiled molecule (Figure 4B), although smaller (2–3 kb) plasmids are essentially equally immune when supercoiled or linearized (data not shown).

We interpret these results to suggest that the proteins responsible for target immunity (i.e. TnsB and TnsC) interact by random collision through space. Thus, the Tn7 end-containing target DNA does not appear to be involved in propagating a signal between TnsB and TnsC. Instead, the DNA likely serves to increase the concentration of TnsB in the vicinity of TnsC.

### TnsB can inactivate preassembled complexes on Tn7 end-containing targets

In all of the experiments presented above, target immunity is most effectively imposed when TnsB is present in the target preincubation. Why is the timing of TnsB’s addition so critical? It is possible that the establishment of target immunity requires a specific order of events. For example, TnsB might need to bind to the target DNA before TnsC (particularly if TnsB’s mode of action were to block the binding of TnsC to Tn7 end-containing targets). On the other hand, the order of events might not be critical, but some time might be required for TnsB to exert its effects.

To investigate these issues, we asked whether TnsB could impose immunity on target DNAs that had been preassembled with TnsC, and what the time course of that inactivation would be. These experiments were performed with the TnsC<sup>A225V</sup> mutant, to focus on the interactions of TnsB and TnsC in the absence of TnsD; however, we have observed similar results in reactions with TnsC+D (see below). The staging of the transposition reaction was altered (Figure 5A): instead of adding TnsB and TnsC<sup>A225V</sup> simultaneously to the target preincubation, TnsC<sup>A225V</sup> was added first. After 20 min, TnsB was added and the target preincubations were continued for various times. Transposition was then initiated by adding the donor preincubation mix. The relative amount of insertion into the Tn7 end-containing target was determined by Southern blotting and phosphorimager analysis; this ‘target reactivity’ is presented graphically as a function of the time the preincubation was extended upon the addition of TnsB.

The reactivity of Tn7 end-containing targets fell sharply when TnsB was added to the target preincubation (Figure 5B, filled circles), suggesting that TnsB can functionally inactivate the preassembled TnsC<sup>A225V</sup>–target complexes. However, the effects of TnsB were not instantaneous: the degree of target inactivation increased with increasing time of exposure to TnsB. As a control for the stability of the target complexes, the preincubations of an identical set of reactions were extended without the addition of TnsB. Under these conditions, the Tn7 end-containing target DNAs maintained at least 80% of their activity (Figure 5B, open circles). This result suggests that the binding of TnsC<sup>A225V</sup> to target DNA is fairly stable in the absence of TnsB, a hypothesis that has been verified by pulse–chase analysis (A.Stellwagen and N.L.Craig, in preparation). However, the presence of TnsB affects the reactivity of the TnsC<sup>A225V</sup>–target DNA complexes over

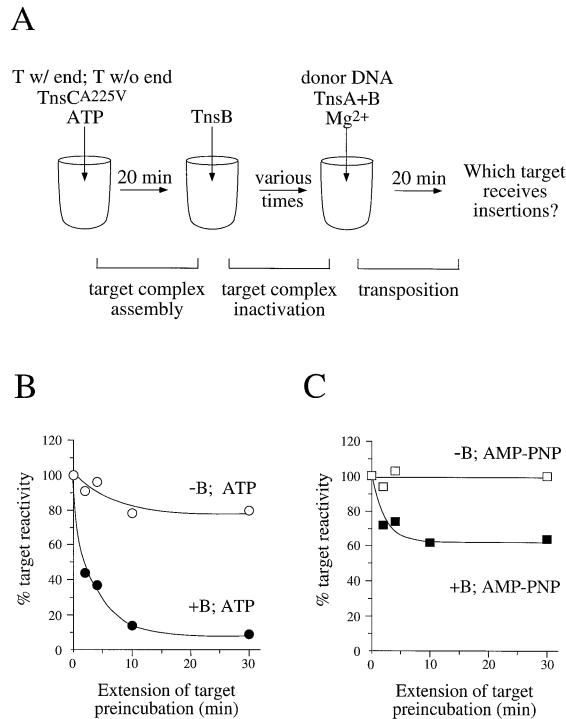

**Fig. 5.** TnsB can inactivate Tn7 end-containing targets which have preassembled with TnsC. **(A)** The staging of the reaction. Parallel sets of reactions were set up, in which TnsC<sup>A225V</sup> was preincubated with a mixture of target DNAs with (pRM2L) and without (pKAO4-3) Tn7 ends. After 20 min, 0.5× TnsB was added to one set of target preincubations but not to the other; the target preincubations were then extended for 0–30 min. Donor preincubations were as described for Figure 3. Transposition was initiated by combining the donor and target preincubations. If 0.5× TnsB had not been added to the target preincubation, it was added at this time. The incubations were continued for another 20 min, the reactions were then stopped and the DNAs collected and analyzed. **(B)** The effect of TnsB on the reactivity of Tn7 end-containing target DNAs preassembled with TnsC<sup>A225V</sup> in the presence of ATP. Reaction products were displayed on a Southern blot and the amount of insertion into the two target DNAs was quantitated by phosphorimager analysis. Relative target reactivity was calculated by dividing the amount of insertion into the target with Tn7 ends by the total amount of insertion into both targets. The reactivity of the Tn7 end-containing target DNA after the first 20 min of preincubation (i.e. before TnsB's introduction) was defined as 100%, and the change in % target reactivity is plotted as a function of the time the target preincubation was extended in the presence (filled symbols) or absence (open symbols) of TnsB. **(C)** Effect of TnsB on the reactivity of Tn7 end-containing target DNAs preassembled with TnsC<sup>A225V</sup> in the presence of AMP-PNP. Target reactivities were determined as in (B).

time. We will argue below that TnsB also affects the stability of these complexes.

The ability of TnsB to inactivate the TnsC<sup>A225V</sup>–target DNA complexes was also found to be affected by the type of ATP nucleotide present in the reaction. TnsC is an ATP-dependent DNA-binding protein with a modest ATPase activity (Gamas and Craig, 1992; A.Stellwagen and N.L.Craig, in preparation). Non-hydrolyzable ATP analogs are known to increase TnsC's affinity for DNA (Gamas and Craig, 1992) and to compromise immunity in TnsABC+D transposition reactions (Bainton *et al.*, 1993). Here, we found that TnsB was much less successful at imposing immunity on TnsC<sup>A225V</sup>–target complexes that were assembled in the presence of the non-hydrolyzable analog AMP-PNP (Figure 5C). The reactivity of

the Tn7 end-containing target dropped only 2-fold upon prolonged (30 min) exposure to TnsB (Figure 5B, filled squares), in contrast to the 11-fold loss of activity seen in reactions with ATP (Figure 5B, filled circles). These results suggest that the interactions between TnsB and TnsC that confer immunity to a target DNA involve TnsC's ability to hydrolyze ATP.

TnsB can also impose immunity on target DNAs preassembled with TnsC+D (data not shown). The rates of target inactivation were similar in reactions with TnsC<sup>A225V</sup> and TnsC+D, and non-hydrolyzable ATP analogs severely reduced the effects of TnsB in both reactions. In fact, with the exception of their TnsD-dependence (and thus their target site specificity), we have found TnsABC<sup>A225V</sup> and TnsABC+D reactions to behave similarly throughout this work. Therefore, we speculate that similar interactions underlie target immunity in both the TnsABC+D and TnsABC<sup>A225V</sup> reactions.

### TnsB promotes the recycling of target binding proteins

How does TnsB inactivate Tn7 end-containing target DNAs? Some possible mechanisms would include: (i) dissociating TnsC from the target DNA; (ii) inactivating TnsC molecules bound to the target; or (iii) obstructing TnsC's interactions with the Tn7 transposase. A mechanism that involves the dissociation of TnsC from the target DNA might be advantageous to Tn7: TnsC could then potentially recycle and reassociate with other, more favorable, target DNAs, rather than being trapped on the Tn7 end-containing target. On the other hand, TnsC's interactions with TnsD might keep TnsC tethered to the Tn7 end-containing target DNA.

We looked for evidence of the release of proteins from the Tn7 end-containing target by staggering the addition of target DNAs during the target preincubation. Here we focus on TnsABC+D transposition reactions (Figure 6); reactions with TnsABC<sup>A225V</sup> are discussed below. TnsC+D was preincubated with target #1 in the presence or absence of TnsB. After 20 min, target #2 was added and the preincubation was continued. This second target functioned as a sink to capture Tns proteins that had been released from target #1. Transposition was initiated by adding the donor preincubation mix, and the level of insertion into the two targets was compared. If TnsB promotes the removal and recycling of proteins (TnsC and/or others) from the Tn7 end-containing target, then we would predict that the use of the second target would increase when immunity was turned ON by the inclusion of TnsB in the target preincubation. However, if TnsB causes the permanent inactivation of proteins that associate with the Tn7 end-containing target, we would expect the use of the second target to be unchanged when immunity was applied. A limiting concentration of TnsC was used in these experiments, so that (when immunity was OFF) most of the protein would interact with the first target, therefore the use of the second target would be low. By contrast, TnsD was present in excess and preincubated with both target DNAs (see Figure 6A and legend for details), so that the use of the second target would depend on the recycling of TnsC but not the recycling of TnsD.

Figure 6B shows the distribution of insertions between a target with Tn7 ends (target #1) and a target without

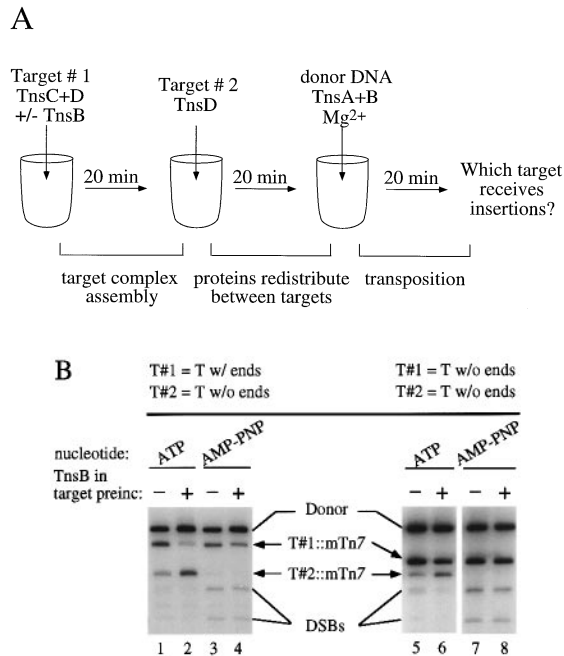

**Fig. 6.** TnsB increases the use of target DNAs added late into the target preincubation. **(A)** The staging of the reaction. Two target DNAs were introduced into the reaction at different times.  $1\times$  TnsC (5 ng) and  $0.5\times$  TnsD (11 ng) were preincubated with target #1 in the presence of ATP or AMP-PNP. After 20 min, target #2 (which had been separately preincubated with  $0.5\times$  TnsD) was added to each reaction, and the target preincubation was continued for another 20 min.  $0.5\times$  TnsB was added to the target preincubation (even lanes) or added after the donor and target preincubations were combined (odd lanes). Donor preincubations were as described for Figure 3. After a further 20 min incubation, the reactions were stopped and the DNAs collected and analyzed. **(B)** Transposition reactions. Lanes 1–4: a Tn7 end-containing target (pRM2L) was added first (T#1), a target without ends (pKAO4-3) was added second (T#2). Lanes 5–8: a target without Tn7 ends (pRM2) was added first (T#1), a different target without ends (pKAO4-3) was added second (T#2). The nucleotide present in each reaction is indicated.

ends (target #2) (lanes 1–4). When the target preincubations were done in the absence of TnsB (lane 1), the majority of insertions (81%) occurred into target #1. This suggests that despite the prolonged target preincubation, most of the TnsC+D remained associated with the first target DNA. However, when TnsB was present in the target preincubation (lane 2), the use of target #2 increased (from 19% to 84% of the total insertions), coincident with immunity being imposed on target #1. The shift in target usage suggests that TnsB does not cause TnsC+D to become permanently inactivated and/or trapped on a Tn7 end-containing target. Instead, functional Tns proteins appear to become available to associate with the second target DNA.

We also examined the recycling of Tns proteins in the presence of the non-hydrolyzable ATP analog AMP-PNP. We have previously shown that target immunity is much less effective when AMP-PNP is substituted for ATP in the Tn7 transposition reaction (Bainton *et al.*, 1993 and Figure 5). If the redistribution of insertions between the first and second targets is a consequence of target immunity, then AMP-PNP should also affect this redistribution. We observed that the commitment of insertions to the first target preincubated with TnsC+D was very strong in the presence of AMP-PNP: 98% of insertions occurred into

target #1 (lane 3). This is consistent with previous observations that TnsC's affinity for DNA is increased when AMP-PNP is substituted for ATP (Gamas and Craig, 1992). The commitment to the first target was maintained even when TnsB was present in the target preincubation; the use of target #2 did not increase (lane 4). Thus, when ATP hydrolysis was blocked, the Tns proteins appear to remain stably and functionally bound to Tn7 end-containing targets despite the presence of TnsB.

A similar redistribution of insertions has also been observed in reactions activated by TnsC<sup>A225V</sup> in the absence of TnsD (data not shown). This result, together with the ATP-dependence of the process, strongly suggests that TnsC is the key protein whose distribution among DNAs is being influenced by TnsB. Therefore, we interpret the insertion patterns seen in these experiments to reflect which target DNAs are bound by TnsC and are therefore capable of interacting with the Tn7 transposase. The fate of TnsD—whether it remains bound to the Tn7 end-containing target DNA or whether it is dislodged along with TnsC—has not yet been resolved.

We also investigated whether TnsB could affect TnsC's distribution among target DNAs without Tn7 ends (Figure 6B, lanes 5–8). In this set of staggered target experiments, TnsC+D was preincubated first with a 3.2 kb target plasmid and a slightly smaller target plasmid was added second; neither of these target DNAs contained a Tn7 end. In the absence of TnsB (lane 5), the majority of insertions (95%) occurred into target #1. However, in the presence of TnsB (lane 6), a modest increase in insertions into target #2 was seen (from 5% to 27%), accompanied by a drop in the use of target #1. This 'evening out' of insertions between the first and second targets was not seen when AMP-PNP was substituted for ATP in these reactions (lanes 7 and 8).

These experiments suggest that TnsB promotes the dissociation of TnsC from target DNAs in general, but that the process is more extensive when a potential target DNA contains Tn7 ends, and thus has a higher local concentration of TnsB. Blocking TnsC's ability to hydrolyze ATP appears to immobilize it on a target DNA, reducing TnsB's effectiveness both at imposing immunity and redistributing insertions to alternative target DNAs.

## Discussion

This work has investigated the mechanism by which target DNAs containing Tn7 ends are rendered 'immune' to Tn7 transposition. The transposon end-binding protein TnsB and the ATP-dependent DNA-binding protein TnsC were found to be central to the recognition and avoidance of Tn7 end-containing target DNAs. TnsC interacts with both the target DNA and the TnsA+B transposase to assemble an active transposition complex; only after this complex is built can Tn7 transposition be initiated (Bainton *et al.*, 1993). An attractive model (illustrated in Figure 7) that emerges from this work is that TnsB dissociates TnsC from target DNAs containing Tn7 ends, leaving those target DNAs unable to interact successfully with the TnsA+B transposase and thus immune to Tn7 transposition. TnsC molecules that have dissociated from a Tn7 end-containing target can recycle and reassociate with other target DNAs. Therefore, target immunity is an



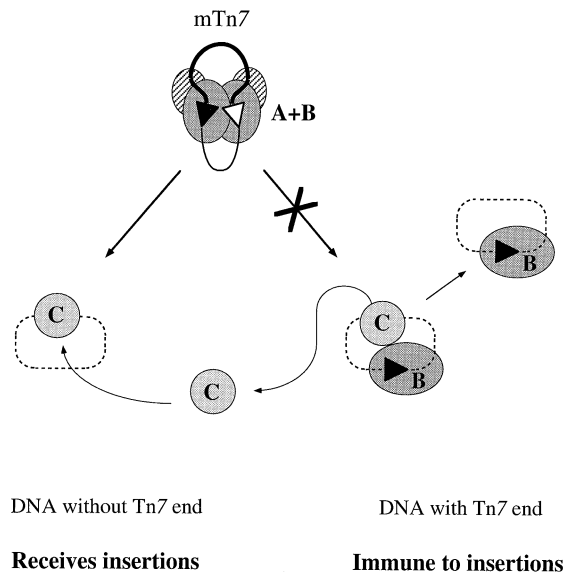

**Fig. 7.** Model for Tn7 target immunity. Potential target DNAs with and without Tn7 ends are cartooned. The Tn7 end-containing target DNA is initially bound by both TnsB and TnsC; interactions between TnsB and TnsC are proposed to trigger the dissociation of TnsC from the Tn7 end-containing target DNA. Displaced TnsC molecules can recycle and reassociate with other target DNAs, so that at equilibrium, TnsC is predominantly localized on targets without Tn7 ends. Therefore, only the target DNAs without Tn7 ends are able to interact with the mTn7 transposon (drawn here with its ends synapsed and bound by the TnsA+B transposase) and initiate transposition.

economical form of target site selection for Tn7, resulting not in the permanent inactivation of TnsC but in its redistribution to more favorable targets. This model has many similarities to the model proposed for target immunity in Mu transposition (Adzuma and Mizuuchi, 1988); comparisons between these and other systems will be discussed in detail below.

#### **Tn7 target immunity: the TnsB signal**

We have demonstrated that the association of TnsB with Tn7 end-containing target plasmids discourages transposition from occurring into those target plasmids *in vitro*. Importantly, we have also shown that TnsB can confer immunity to a target plasmid that is catenated to (but not continuous with) a Tn7 end-containing plasmid. This result argues strongly that TnsB and the proteins present at the insertion site (TnsC and/or others) communicate by protein–protein interactions rather than by tracking or signaling along the DNA. Therefore, ‘immune’ targets are simply those DNAs which have a high local concentration of TnsB, and consequently a high frequency of interaction between TnsB and the proteins at the insertion site.

In the bacterial chromosome, immunity can operate over impressive DNA distances: a Tn7 end can reduce the frequency of transposition into sites up to 190 kb away (DeBoy and Craig, 1996). The effects of TnsB do not appear to be uniform over this distance; an inverse correlation was found between the magnitude of the immunity effect and the distance between the Tn7 ends and the *attTn7* target site in the chromosome (DeBoy and Craig, 1996). Variations in relative TnsB concentration may contribute to the effects of distance on target immunity *in vivo*. Chromosomal regions in close linear and/or

physical proximity to Tn7 ends would be in a zone of comparatively high TnsB concentration and thus would undergo a strong immune response. By contrast, chromosomal regions separated from the Tn7 ends by large DNA distances or chromosomal condensation would have very few interactions with TnsB and would not be immune to insertions.

Target immunity *in vitro* was found to depend on the number of TnsB binding sites present on the target DNA; the stability with which TnsB binds to those sites is likely also involved. Furthermore, we found that time is also required to establish immunity: several minutes were needed for TnsB to fully inactivate the Tn7 end-containing targets (Figure 5). This is the same time frame needed for a mTn7 element, TnsA and TnsB to assemble with a target complex and initiate transposition (Bainton *et al.*, 1993; A.Stellwagen and N.L.Craig, unpublished data). Thus, TnsB is involved in two processes—target inactivation and target use—which appear to occur at similar rates. In the test tube, immunity is efficiently established when these processes are temporally separated, through the careful staging of the transposition reactions. It will be interesting and challenging to discover whether the timing of TnsB’s interactions with target DNA complexes is also important for target immunity in the cell.

#### **Tn7 target immunity: the response to TnsB**

Our experiments suggest that TnsB imposes target immunity through its interactions with TnsC. We observed that target immunity was severely compromised in the presence of non-hydrolyzable ATP analogs, yet TnsB itself has no known interactions with ATP (Gamas and Craig, 1992; A.Stellwagen and N.L.Craig, unpublished data). Therefore, ATP hydrolysis appears to be important not in the TnsB signal but in the response to TnsB. TnsC, the only Tn7-encoded protein known to interact with ATP, is strongly implicated to be involved in that response. Support for the critical role of TnsC also comes from the observations of target immunity in reactions with TnsABC<sup>A225V</sup> in the absence of TnsD. Although several mechanisms can be imagined by which TnsB could interact with TnsC to inactivate a potential target DNA, perhaps the most attractive model to explain the data is that TnsB triggers the dissociation of TnsC from Tn7 end-containing target DNAs.

How might TnsB affect TnsC’s association with DNA? The ATP state of TnsC has been demonstrated to regulate its DNA-binding activity: TnsC+ATP is competent to bind DNA, whereas TnsC+ADP is not (Gamas and Craig, 1992). TnsC also has a modest ATPase activity (A.Stellwagen and N.L.Craig, in preparation), enabling TnsC to switch between the ATP- and ADP-bound states. TnsB could promote the removal of TnsC from a potential target DNA molecule by influencing TnsC’s ATP interactions—for example, by stimulating TnsC’s rate of ATP hydrolysis—or by facilitating TnsC’s dissociation from DNA following ATP hydrolysis. Either possibility would explain why non-hydrolyzable ATP analogs reduce TnsC’s ability to respond to TnsB.

The effects of ATP binding and hydrolysis on TnsC’s activities are reminiscent of the actions of molecular switch proteins, whose ability to participate in various biological processes is controlled by hydrolysis of ATP

or GTP. A classic example of a molecular switch is p21-Ras, a GTPase that regulates many signal transduction cascades (Bourne *et al.*, 1990, 1991). GTP hydrolysis enables Ras to switch from an active to an inactive conformation; the rate at which Ras switches between conformations is modulated by GTPase-activating proteins (GAPs) and GTP-GDP exchange factors (GEFs). We propose that TnsC acts as a molecular switch to regulate Tn7 transposition, and we are very interested in determining whether TnsC's ATP interactions are modulated by other Tns proteins. For example, TnsB could be the functional equivalent of a GAP, promoting ATP hydrolysis and thus TnsC inactivation, while other factors (perhaps TnsD) might stabilize the ATP-bound form of TnsC.

### **Comparison of target immunity in Tn7 and Mu**

The proposed mechanism for Tn7 target immunity—the TnsB-dependent removal of TnsC from Tn7 end-containing target DNAs—has many parallels to the mechanism of target immunity described by Adzuma and Mizuuchi (1988, 1989) for the bacteriophage Mu. Mu transposition is executed by the MuA transposase, which directs insertions into target DNAs bound by MuB, an ATP-dependent DNA-binding protein (Chaconas *et al.*, 1985; Maxwell *et al.*, 1987). However, MuB is actively removed from target DNAs containing Mu ends: MuA, bound to the Mu end, stimulates MuB's ATPase activity and promotes MuB's dissociation from those target DNAs (Maxwell *et al.*, 1987; Adzuma and Mizuuchi, 1988). Thus, there are strong similarities between the interactions of MuA and MuB and the interactions of TnsB and TnsC in establishing target immunity. In both cases, immunity can be conferred to a target DNA that is catenated to a transposon end (Adzuma and Mizuuchi, 1989 and this work), suggesting that high local concentrations of the end-binding protein (MuA or TnsB) are responsible for immunity in each system.

These mechanistic similarities are striking since Mu and Tn7 proteins generally have very little primary sequence homology, although specific proteins sometimes share functional motifs. For example, MuB and TnsC both contain motifs commonly found in nucleotide binding proteins (Walker *et al.*, 1982; Chaconas *et al.*, 1985; Flores *et al.*, 1990), but otherwise the amino acid sequences of MuB and TnsC are widely divergent.

MuB and TnsC also have an important functional difference: whereas MuB is sufficient to activate its transposase, TnsC is not. Instead, Tn7 transposition is dependent on multiple target selection factors, which direct Tn7 transposition to different types of target sites (Rogers *et al.*, 1986; Waddell and Craig, 1988; Wolkow *et al.*, 1996). Interestingly, these extra complexities do not appear to override or interfere with the basic immunity mechanism shared by Mu and Tn7. In fact, we will argue below that Tn7 actually exploits the interactions that underlie target immunity to facilitate its selection of preferred target sites.

### **The target immunity paradox**

Target immunity poses a molecular paradox: the same proteins that discourage transposition from occurring into target DNAs containing transposon ends are also responsible for promoting transposition into target DNAs without ends. For example, MuA bound to Mu ends in a donor

molecule readily captures and utilizes MuB–target DNA complexes, but MuA bound to a Mu end on a target DNA destroys the MuB–target DNA complex (Adzuma and Mizuuchi, 1988). The situation is even more perplexing for Tn3, in which transposition and immunity are accomplished by a single transposon-encoded protein (Gill *et al.*, 1979; Lee *et al.*, 1983; Maekawa *et al.*, 1996).

The study of Tn7 target immunity may have given us some insight into this paradox. Tn7's transposition activities are distributed among many proteins, and different combinations of these proteins appear to mediate target use versus target immunity. Promoting transposition requires both TnsA and TnsB: the active sites responsible for DNA breakage and joining appear to be divided between TnsA and TnsB and the catalytic activities of TnsA and TnsB are interdependent (May and Craig, 1996; Sarnovsky *et al.*, 1996). By contrast, the requirements for target immunity appear to be more minimal: TnsB bound to a single transposon end can interact with TnsC to prevent target use; TnsA does not appear to be involved. Future work is needed to determine whether the interaction(s) between TnsA+B and TnsC that result in transposition are the same or different from the interaction(s) between TnsB and TnsC that result in immunity. Toward that end, it would be very interesting to screen for TnsB mutants that retain the ability to promote transposition but fail to promote target immunity.

### **Comparison with other mechanisms for silencing DNA**

Tn7 and Mu achieve target immunity by preventing a region of DNA from being able to engage the transposition machinery. This phenomenon is conceptually similar to transcriptional silencing, in which regions of the chromosome—for example, the silent mating type loci and telomeres in yeast—become unable to engage the transcriptional machinery. Silent chromosomal regions are packaged in specialized heterochromatin-like structures that render the DNA inaccessible to many proteins, including the basal transcriptional machinery (reviewed in Loo and Rine, 1995; Zakian, 1996). Thus, genes within silent chromatin are unable to interact with RNA polymerase, just as target sites on immune plasmids are unable to interact with transposase. Although the outcomes of these two processes are similar, the strategies used to achieve the 'silent' state are significantly different: transcriptional silencing involves the assembly of an inactive protein–DNA structure, whereas target immunity involves the disassembly of an active structure.

### **Tn7 transposition: extending the immunity mechanism to multiple forms of target site selection**

Tn7 and Mu both evaluate potential target DNAs for negative signals, namely the presence of transposon ends. However, Tn7 is uniquely able to evaluate potential target DNAs for positive signals. Tn7 transposition is preferentially directed into *attTn7* sequences or into plasmids undergoing conjugation (Barth *et al.*, 1976; Hauer and Shapiro, 1984; Wolkow *et al.*, 1996). We propose that the interactions between TnsB and TnsC described in this work may facilitate all of these types of Tn7 target site selection. By promoting TnsC's dissociation

from DNA in general and from immune targets in particular (Figure 6B), TnsB increases TnsC's ability to 'sample' the various target molecules present in the cell or the test tube. Therefore, TnsC would be more likely to find favorable target sites (such as *attTn7*) and less likely to be trapped on unfavorable targets.

Non-hydrolyzable ATP analogs, by contrast, appear to reduce TnsC's ability to sample different target DNAs. In the presence of AMP-PNP, TnsC appears to be locked in an active conformation; its affinity for DNA is increased (Gamas and Craig, 1992) but its ability to respond to the positive and negative features of a potential target DNA is decreased. Therefore, Tn7 is less successful at finding *attTn7* target sites in the presence of AMP-PNP (Bainton *et al.*, 1993), as well as less successful at avoiding Tn7 end-containing targets.

In conclusion, our investigations into the mechanism of target immunity may have revealed a theme that is common to all forms of Tn7 target site selection: the importance of controlling the distribution of TnsC. Although TnsC binds to DNA with no particular sequence specificity (Gamas and Craig, 1992), its localization among target DNAs is hardly random. TnsC is recruited to *attTn7* sites by TnsD; the formation of TnsC-TnsD-*attTn7* complexes has been documented by DNA protection and mobility shift assays (Bainton *et al.*, 1993). TnsC may be similarly recruited to conjugating plasmids by TnsE. Finally, experiments in this work suggest that TnsC is removed from Tn7 end-containing targets by TnsB. Therefore, we speculate that TnsC's distribution is a molecular reflection of the positive and negative features of the available target DNAs, and provides a means of attracting the Tn7 transposase to the most favorable targets.

## Materials and methods

### DNA substrates

The donor plasmid pEMA (5.9 kb) contains a 1.6 kb mini-Tn7 element (mTn7), in which 166 bp from the left end of Tn7 and 199 bp from the right end of Tn7 flank a kanamycin resistance marker (Bainton *et al.*, 1993). All of the target plasmids used in this work are derivatives of pUC (except the catenation plasmids, which are derivatives of pBR322). The target plasmids pKAO4-3 (2.8 kb) and pRM2 (3.2 kb) contain the sequences necessary for *attTn7* target activity (McKown *et al.*, 1988). The target plasmid pLA11 (3.6 kb) was derived from pRM2, and contains a Tn7 right end (including the R1-199 sequences) located ~1 kb from the *attTn7* site (Bainton *et al.*, 1991). The target plasmid pRM2L (3.7 kb) was generated in this study by cloning the *HindIII*-*ScaI* fragment from pLA19 (Arciszewska *et al.*, 1989), containing L1-166 sequences, into pRM2. The left end sequences in the resulting plasmid were ~0.8 kb from the *attTn7* site. The plasmids pLA62 (2.8 kb) and pLA77 (3.1 kb) contain the sequences R38-199 from the Tn7 right end and L109-166 from the Tn7 left end, respectively (Arciszewska *et al.*, 1989, 1991); these plasmids do not contain *attTn7* sites.

The catenation-competent plasmid pRCAT2 (4.8 kb) was constructed in two steps. First, an *EcoRI*-*Sall* fragment from pEMA, containing R1-199 sequences, was cloned into pNG210 (Boocock *et al.*, 1995) to generate pRCAT1. An *attTn7* site was then introduced by replacing the *AflIII*-*NdeI* fragment of pRCAT1 with the *AflIII*-*NdeI* fragment from pKAO4-3. The right end sequences and the *attTn7* site were ~2.2 kb apart in the resulting plasmid pRCAT2.

### Tns proteins

TnsA was purified as a fusion with glutathione S-transferase (GST) and then released from the GST moiety by thrombin cleavage (May and Craig, 1996). TnsA was stored at -80°C in 25 mM HEPES, pH 7.5, 1 mM EDTA, 150 mM NaCl, 1 mM DTT, 5% glycerol and 0.25 mM PMSF. TnsB was TnsB-His<sub>6</sub> (Gary *et al.*, 1996) and was stored in

25 mM HEPES, pH 7.5, 500 mM KCl, 2 mM DTT, 1 mg/ml BSA and 25% glycerol. TnsC was fraction III (Gamas and Craig, 1992) and was stored in 25 mM HEPES, pH 7.5, 1 M NaCl, 2.5 mM DTT, 1 mM ATP, 10 mM MgCl<sub>2</sub>, 0.1 mM EDTA, 10 mM CHAPS and 10% glycerol. Before use, TnsC was diluted 1:5 in a buffer identical to the storage buffer except without ATP. TnsD was TnsD-His (Sarnovsky *et al.*, 1996; P.L.Sharpe and N.L.Craig, in preparation) and was stored in 50 mM Tris, pH 7.5, 2 mM DTT, 500 mM KCl, 1 mM EDTA and 25% glycerol.

The TnsC<sup>A225V</sup> mutation was introduced into the TnsC expression vector pPA101 (Gamas and Craig, 1992) by replacing the *HindIII* fragment of pPA101 with the 1.9 kb *HindIII* fragment from a pCW15 plasmid containing the TnsC<sup>A225V</sup> mutation (Stellwagen and Craig, 1997). TnsC<sup>A225V</sup> was expressed and purified using the protocol developed for TnsC (Gamas and Craig, 1992). One modification was introduced: the ammonium sulfate pellet was extracted twice with Buffer A (containing 0.1 M NaCl) prior to resuspension in the storage buffer, rather than the ammonium sulfate pellet being resuspended in Buffer B + 1.0 M NaCl, reprecipitated by dialysis into Buffer B + 0.1 M NaCl, and then resuspended in the storage buffer. This modification has also been used when purifying wild-type TnsC; no change in protein activity has been observed but the protein yields are increased (A.Stellwagen and N.L.Craig, unpublished data).

### Tn7 transposition in vitro

Reactions were adapted from the procedure of Bainton *et al.* (1993). The final reaction mixture (100 µl) contained 0.25 nM pEMA donor DNA, 0.83 nM each of various target DNAs, 26 mM HEPES, pH 7.5, 3.3 mM Tris, pH 7.5, 2.1 mM DTT, 70 µg/ml BSA, 0.06 mM EDTA, 0.1 mM MgCl<sub>2</sub>, 0.1 mM CHAPS, 12 mM NaCl, 15 mM KCl, 0.9% glycerol, 4 µM PMSF, 2 mM nucleotide (ATP or AMP-PNP) and 15 mM MgAc unless otherwise indicated. Tns proteins (1-2 µl each) were added to the following final amounts, unless otherwise indicated: 60 ng TnsA, 25 ng TnsB, 10 ng TnsC (or 20 ng TnsC<sup>A225V</sup>) and 20 ng TnsD.

The order of addition of the DNA substrates and the Tns proteins was varied in different experiments; details are provided in the figure legends. The general strategy was to preincubate the donor and target DNAs separately with different subsets of Tns proteins, and then to combine the preincubated DNAs to initiate transposition. Target preincubations (50 µl) usually contained TnsC and TnsD (or TnsC<sup>A225V</sup> and an equivalent volume of TnsD buffer) in the presence or absence of TnsB (at 0.5× its final concentration, i.e. 12.5 ng). ATP (or AMP-PNP, when indicated) was added to the target preincubations; MgAc was not. The donor preincubations (50 µl) always contained TnsA, 0.5× TnsB and 15 mM MgAc. Donor and target preincubations were carried out for 20 min at 30°C unless otherwise indicated. The preincubations were then combined, the MgAc concentration was adjusted back to 15 mM, and any proteins which had been omitted from the target preincubation (i.e. 0.5× TnsB) were added. Therefore, the final composition of all reactions in a given experiment was always the same. Reactions were incubated for another 20 min and then stopped with the addition of 100 µl phenol:chloroform.

The DNAs from a transposition reaction were collected by ethanol precipitation, subjected to *NdeI* digestion (unless otherwise indicated) and loaded on a 0.6% TBE agarose gel. 0.05 µCi of a <sup>32</sup>S-labeled DNA ladder (Amersham) was included on each gel. Electrophoresis proceeded at 2 V/cm for 15 h, to obtain good separation in the relevant size range. The DNAs were transferred to Gene Screen Plus (NEN Research Products) by capillary transfer. Blots were hybridized with a mTn7-specific probe, namely the kanamycin resistance cassette which is contained within mTn7. Probes were labeled by random priming with [ $\alpha$ -<sup>32</sup>P]dCTP and the Klenow fragment of DNA polymerase I (BMB). Blots were analyzed by autoradiography using Kodak BioMax MR film or by a Molecular Dynamics Phosphorimager.

### $\gamma\delta$ Resolution reactions

The  $\gamma\delta$  resolution reactions were performed essentially as described by Reed (1981). Reaction mixtures (100 µl) contained 3 µg pRCAT2, 22 mM Tris, pH 8.0, 10 mM MgCl<sub>2</sub>, 100 mM NaCl, 5% glycerol and 200 ng  $\gamma\delta$  resolvase protein (a gift from Nigel Grindley). Reactions were incubated at 37°C for 60 min. The reaction mixture was then split, and half of the material was digested with *NdeI*. All reactions were stopped by incubation with 0.4 mg/ml proteinase K in 0.25% SDS and 20 mM EDTA, followed by heat-inactivation. DNAs were recovered by two rounds of phenol:chloroform extraction, ethanol precipitation and resuspension in TE. The efficiency of the resolution reaction and the concentration of the resolved and unresolved products were evaluated by agarose gel electrophoresis.

## Acknowledgements

We gratefully thank Dr Nigel Grindley for providing *res*-containing plasmids,  $\gamma\delta$  resolvase and advice. We thank Jef Boeke, Steve Desiderio, Tom Kelly and members of the Craig Laboratory for comments on the manuscript. This work was supported by grant GM53824 (N.L.C.) from the National Institutes of Health. N.L.C. is an Investigator with the Howard Hughes Medical Institute. A.E.S. is a graduate student in the Department of Biochemistry, University of California, San Francisco.

## References

- Adzuma,K. and Mizuuchi,K. (1988) Target immunity of Mu transposition reflects a differential distribution of MuB protein. *Cell*, **53**, 257–266.
- Adzuma,K. and Mizuuchi,K. (1989) Interaction of proteins located at a distance along DNA: mechanism of target immunity in the Mu DNA strand-transfer reaction. *Cell*, **57**, 41–47.
- Arciszewska,L.K., Drake,D. and Craig,N.L. (1989) Transposon Tn7 *cis*-acting sequences in transposition and transposition immunity. *J. Mol. Biol.*, **207**, 35–52.
- Arciszewska,L.K. and Craig,N.L. (1991) Interaction of the Tn7-encoded transposition protein TnsB with the ends of the transposon. *Nucleic Acids Res.*, **19**, 5021–5029.
- Arciszewska,L.K., McKown,R.L. and Craig,N.L. (1991) Purification of TnsB, a transposition protein that binds to the ends of Tn7. *J. Biol. Chem.*, **266**, 21736–21744.
- Bainton,R.J., Gamas,P. and Craig,N.L. (1991) Tn7 transposition *in vitro* proceeds through an excised transposon intermediate generated by staggered breaks in DNA. *Cell*, **65**, 805–816.
- Bainton,R.J., Kubo,K.M., Feng,J.N. and Craig,N.L. (1993) Tn7 transposition: Target DNA recognition is mediated by multiple Tn7-encoded proteins in a purified *in vitro* system. *Cell*, **72**, 931–943.
- Barth,P.T., Datta,N., Hedges,R.W. and Grinter,N.J. (1976) Transposition of a deoxyribonucleic acid sequence encoding trimethoprim and streptomycin resistances from R483 to other replicons. *J. Bacteriol.*, **125**, 800–810.
- Boocock,M.R., Zhu,X. and Grindley,N.D.F. (1995) Catalytic residues of  $\gamma\delta$  resolvase act in *cis*. *EMBO J.*, **14**, 5129–5140.
- Bourne,H.R., Sanders,D.A. and McCormick,F. (1990) The GTPase superfamily: a conserved switch for diverse cell functions. *Nature*, **348**, 125–132.
- Bourne,H.R., Sanders,D.A. and McCormick,F. (1991) The GTPase superfamily: conserved structure and molecular mechanism. *Nature*, **349**, 117–127.
- Chaconas,G., Gloor,G. and Miller,J.L. (1985) Amplification and purification of the bacteriophage Mu encoded B transposition protein. *J. Biol. Chem.*, **260**, 2662–2669.
- Darzens,A., Kent,N.E., Buckwalter,M.S. and Casadaban,M.J. (1988) Bacteriophage Mu sites required for transposition immunity. *Proc. Natl Acad. Sci. USA*, **85**, 6826–6830.
- DeBoy,R.T. and Craig,N.L. (1996) Tn7 transposition as a probe of *cis* interactions between widely separated (190 kilobases apart) DNA sites in the *Escherichia coli* chromosome. *J. Bacteriol.*, **178**, 6184–6191.
- Flores,C., Qadri,M.I. and Lichtenstein,C. (1990) DNA sequence analysis of five genes; *msA*, *B*, *C*, *D*, and *E*, required for Tn7 transposition. *Nucleic Acids Res.*, **18**, 901–911.
- Gamas,P. and Craig,N.L. (1992) Purification and characterization of TnsC, a Tn7 transposition protein that binds ATP and DNA. *Nucleic Acids Res.*, **20**, 2525–2532.
- Gary,P.A., Biery,M.C., Bainton,R.J. and Craig,N.L. (1996) Multiple DNA processing reactions underlie Tn7 transposition. *J. Mol. Biol.*, **257**, 301–316.
- Gill,R.E., Heffron,F. and Falkow,S. (1979) Identification of the protein encoded by the transposable element Tn3 which is required for its transposition. *Nature*, **282**, 797–801.
- Hauer,B. and Shapiro,J.A. (1984) Control of Tn7 transposition. *Mol. Gen. Genet.*, **194**, 149–158.
- Lee,C.H., Bhagwat,A. and Heffron,F. (1983) Identification of a transposon Tn3 sequence required for transposition immunity. *Proc. Natl Acad. Sci. USA*, **80**, 6765–6769.
- Lichtenstein,C. and Brenner,S. (1982) Unique insertion site of Tn7 in the *E.coli* chromosome. *Nature*, **297**, 601–603.
- Loo,S. and Rine,J. (1995) Silencing and heritable domains of gene expression. *Annu. Rev. Cell Dev. Biol.*, **11**, 519–548.
- Maekawa,T., Yanagihara,K. and Ohtsubo,E. (1996) A cell-free system of Tn3 transposition and transposition immunity. *Genes to Cells*, **1**, 1007–1016.
- Maxwell,A., Craigie,R. and Mizuuchi,K. (1987) B protein of bacteriophage Mu is an ATPase that preferentially stimulates intermolecular DNA strand transfer. *Proc. Natl Acad. Sci. USA*, **84**, 699–703.
- May,E.W. and Craig,N.L. (1996) Switching from cut-and-paste to replicative Tn7 transposition. *Science*, **272**, 401–404.
- McKown,R.L., Orle,K.A., Chen,T. and Craig,N.L. (1988) Sequence requirements of *Escherichia coli attTn7*, a specific site of transposon Tn7 insertion. *J. Bacteriol.*, **170**, 352–358.
- Mizuuchi,K. (1992) Transpositional recombination: mechanistic insights from studies of Mu and other elements. *Annu. Rev. Biochem.*, **61**, 1011–1051.
- Muzi-Falconi,M., Brown,G.B. and Kelly,T.J. (1996) DNA replication: controlling initiation during the cell cycle. *Curr. Biol.*, **6**, 229–233.
- Reed,R.R. (1981) Transposon-mediated site-specific recombination: a defined *in vitro* system. *Cell*, **25**, 713–719.
- Reyes,O., Beyou,A., Mignotte-Vieux,C. and Richaud,F. (1987) Mini-Mu transduction: *cis*-inhibition of the insertion of Mud transposons. *Plasmid*, **18**, 183–192.
- Robinson,M.K., Bennett,P.M. and Richmond,M.H. (1977) Inhibition of TnA translocation by TnA. *J. Bacteriol.*, **129**, 407–414.
- Rogers,M., Ekaterinaki,N., Nimmo,E. and Sherratt,D. (1986) Analysis of Tn7 transposition. *Mol. Gen. Genet.*, **205**, 550–556.
- Sarnovsky,R.J., May,E.W. and Craig,N.L. (1996) The Tn7 transposase is a heteromeric complex in which DNA breakage and joining activities are distributed between different gene products. *EMBO J.*, **15**, 6348–6361.
- Stellwagen,A.E. and Craig,N.L. (1997) Gain-of-function mutations in TnsC, an ATP-dependent transposition protein that activates the bacterial transposon Tn7. *Genetics*, **145**, 573–585.
- Tang,Y., Lichtenstein,C. and Cotterill,S. (1991) Purification and characterisation of the TnsB protein of Tn7: a transposition protein that binds to the ends of Tn7. *Nucleic Acids Res.*, **19**, 3395–3402.
- Waddell,C.S. and Craig,N.L. (1988) Tn7 transposition: two transposition pathways directed by five Tn7-encoded genes. *Genes Dev.*, **2**, 137–149.
- Walker,J.E., Saraste,M., Runswick,M.J. and Gay,N.J. (1982) Distantly related sequences in the alpha- and beta-subunits of ATP synthase, myosin, kinases, and other ATP-requiring enzymes and a common nucleotide binding fold. *EMBO J.*, **1**, 945–951.
- Wang,J.C. and Gjaever,G.N. (1988) Action at a distance along a DNA. *Science*, **240**, 300–304.
- Wolkow,C.A., DeBoy,R.T. and Craig,N.L. (1996) Conjugating plasmids are preferred targets for Tn7. *Genes Dev.*, **10**, 2145–2157.
- Wuarin,J. and Nurse,P. (1996) Regulating S phase: CDKs, licensing and proteolysis. *Cell*, **85**, 785–787.
- Zakian,V.A. (1996) Structure, function, and replication of *Saccharomyces cerevisiae* telomeres. *Annu. Rev. Genet.*, **30**, 141–172.

Received on June 17, 1997; revised on August 28, 1997